

# 6-FMX Series

## Front Terminal Battery

### 6-FMX-50



### Main Applications

- Telecom site
- Outdoor base station
- Floating operation site
- UPS

### Benefits

- Front terminal design, easy access for faster installation and maintenance
- Optimal energy density, save floor space
- No leakage and no acid smog spray during the operation

### Dimensions

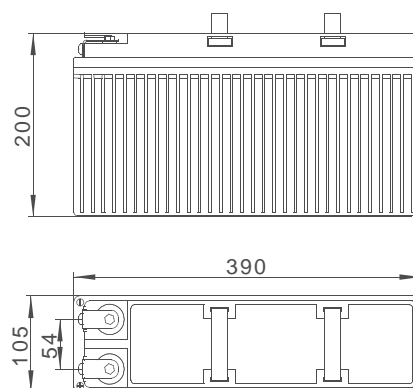

### Technical Parameters

Nominal Voltage	12 V
Capacity	50 Ah @ 10hr to 1.80 V per cell @ 25°C (77°F)
Weight	17.8 kg(39.24 lbs)
Dimensions	Length:390 mm (15.35 in) Width: 105 mm (4.13 in) Height: 200 mm (7.87 in)
Internal Resistance (full charged)	7.0 mΩ
Short-circuit Current	1426 A
Self Discharge @25°C(77°F)	Less than 4% after 30 days storage
Operating Temperature Range	Discharge: -40°C ~ 50°C(-40°F ~ 122°F) Charge: -20°C ~ 45°C(-4°F ~ 113°F) Storage:-20°C ~ 40°C(-4°F ~ 104°F)
Recommended Operating Temperature	15°C ~ 25°C (59°F ~ 77°F)
Recommended Charging Current	10 A
Charging Voltage @25°C(77°F)	Float: 2.23 V/cell Equalize: 2.35 V/cell
Terminal	M6
Container Materials	ABS/ABS V0 (Optional)
Capacity Affected by Temperature(C <sub>10</sub> )	103% @ 40°C(104°F) 85% @ 0°C(32°F) 60% @ -20°C(-4°F)
Design Life @25°C(77°F)	12 years

### Certification

- ISO 9001
- ISO 14001
- GB/T 28001
- UL
- CE

### Technical Features

- Excellent capacity retention rate
- Long life float service design
- Excellent over discharge recovery capability

# 6-FMX Series

## Front Terminal Battery

### 6-FMX-50



#### Constant Current Discharge Characteristics Unit: A (25°C, 77°F)

F.V/Time	30min	1hr	2hr	3hr	4hr	5hr	6hr	8hr	10hr	12hr
1.70V	51.0	28.4	18.6	13.3	10.6	9.0	7.7	6.3	5.3	4.7
1.75V	48.3	27.6	18.3	13.0	10.4	8.8	7.6	6.2	5.2	4.5
1.80V	45.6	27.0	18.1	12.5	10.0	8.5	7.5	6.1	5.0	4.4
1.83V	43.5	25.8	18.0	12.3	9.8	8.3	7.4	5.9	4.9	4.3
1.85V	42.1	25.1	17.8	12.0	9.6	8.2	7.3	5.8	4.8	4.2

#### Constant Power Discharge Characteristics Unit: W/cell (25°C, 77°F)

F.V/Time	30min	1hr	2hr	3hr	4hr	5hr	6hr	8hr	10hr	12hr
1.70V	92.5	52.8	35.6	25.8	20.5	17.8	16.1	12.4	10.9	9.1
1.75V	88.6	51.9	35.4	25.5	20.4	17.5	15.9	12.4	10.7	8.9
1.80V	84.8	51.3	35.2	24.5	19.6	17.0	15.8	12.2	10.6	8.8
1.83V	82.2	49.6	35.0	24.4	19.5	16.7	15.6	11.9	10.5	8.7
1.85V	80.2	48.4	34.8	23.9	19.2	16.6	15.5	11.8	10.4	8.6

#### Performance Curve

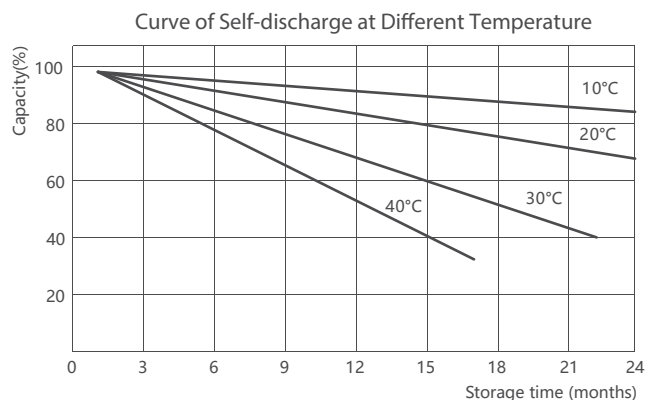
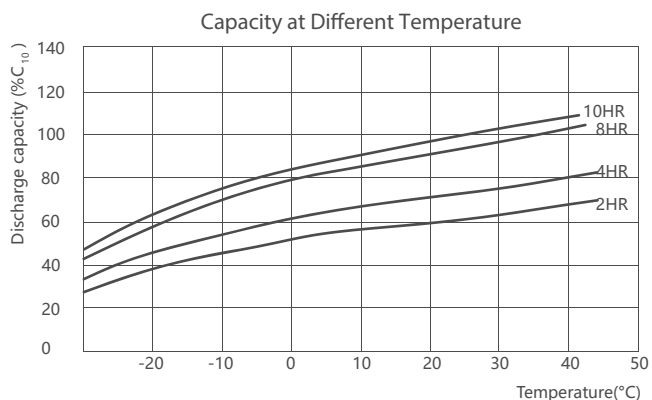
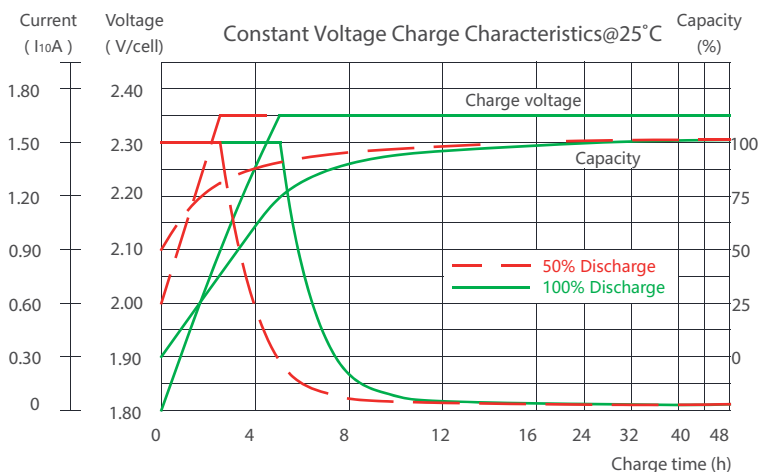
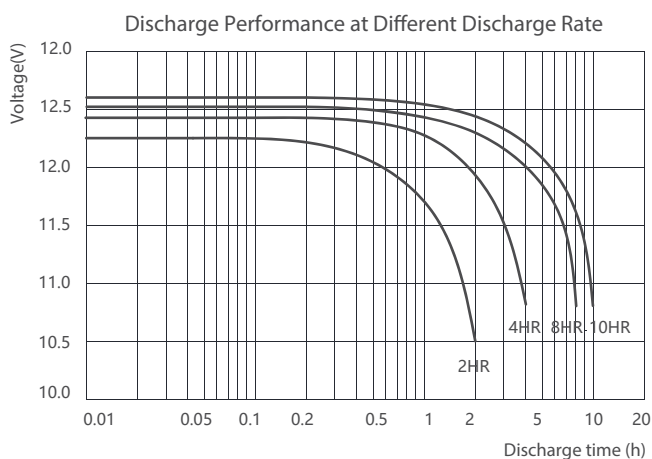

#### \*Declaration:

This information is generally descriptive only and is not intended to make or imply any representation, guarantee or warranty with respect to any cells and batteries. Cell and battery designs/specifications are subject to modification without notice. Contact CHINASHOTO for the latest information.

Welcome to Visit : [www.chinashoto.com](http://www.chinashoto.com)