

Lead-Carbon Battery LLC-400



Main Applications

- ▣ Renewable energy (wind & solar) storage system
- ▣ Peak shifting of electrical power system
- ▣ Frequency regulation and load following service
- ▣ Smart-grid & micro-grid sites
- ▣ Off-grid & bad-grid sites

Benefits

- ▣ Extra long life design, design life is 20 years
- ▣ Superior PSoC and deep cycling performance
- ▣ Excellent quick charge performance, reduce charging time by 30%
- ▣ High potential fuel savings when used with hybrid genset applications

Dimensions

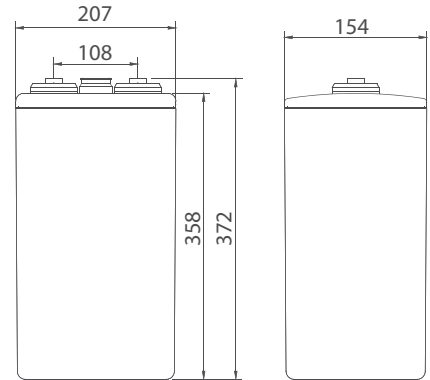

Technical Parameters

Nominal Voltage	2 V
Capacity	400 Ah @ 10hr to 1.80 V@ 25°C (77°F)
Weight	28.3kg (62.39 lbs)
Dimensions	Length: 154 mm (6.06 in) Width: 207 mm (8.15 in) Height: 358 mm (14.09 in) Total height: 372 mm (14.65 in)
Internal Resistance (full charged)	0.38mΩ
Short- circuit Current	6800 A
Self Discharge @25°C(77°F)	Less than 4% after 30 days storage
Operating Temperature Range	Discharge: -40°C ~ 50°C(-40°F ~ 122°F) Charge: -20°C ~ 45°C(-4°F ~ 113°F) Storage:-20°C ~ 40°C(-4°F ~ 104°F)
Recommended Operating Temperature	15°C ~ 25°C (59°F ~ 77°F)
Recommended Charging Current	60 A
Maximum Charging Current	120 A
Charging Voltage @25°C(77°F)	Float: 2.23 V/cell Equalize: 2.35 V/cell
Terminal	M8
Container Materials	ABS/ABS V0 (Optional)
Capacity Affected by Temperature(C ₁₀)	105% @ 40°C(104°F) 85% @ 0°C(32°F) 60% @ -20°C(-4°F)
Design Life @25°C(77°F)	20 years

Certification

- IEC 61427
- IEC 60896
- UL
- CE

Technical Features

- ▣ Adopt lead- carbon capacitance technology, reduce the cathode sulphation, ideal for PSoC cycle application and can deliver 4~5 times better cyclic life compared with normal VRLA
- ▣ Better charge acceptability and faster recharge performance
- ▣ Exquisite design for premium quality, high reliability and stability

Lead-Carbon Battery LLC-400



Constant Current Discharge Characteristics Unit: A (25°C, 77°F)

F.V/Time	15min	30min	1hr	3hr	5hr	8hr	10hr	20hr	48hr
1.75V	486	338	222	106	74	51	42	23.1	9.8
1.80V	430	316	214	103	72	50	42	22.7	9.7
1.85V	372	281	193	98	69	49	41	21.9	9.4
1.90V	298	226	166	82	58	41	34	19.4	9.1

Constant Power Discharge Characteristics Unit: W/cell (25°C, 77°F)

F.V/Time	15min	30min	1hr	3hr	5hr	8hr	10hr	20hr	48hr
1.75V	825	651	414	208	139	95	84	45.2	20.6
1.80V	790	566	406	203	138	94	82	44.8	20.2
1.85V	711	527	397	193	135	93	79	42.5	19.5
1.90V	573	423	344	165	115	82	67	38.6	18.2

Performance Curve

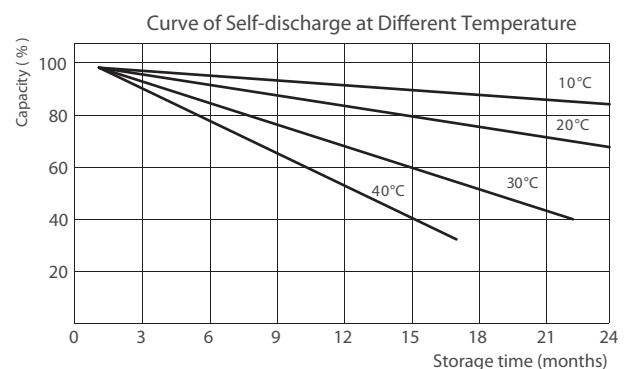
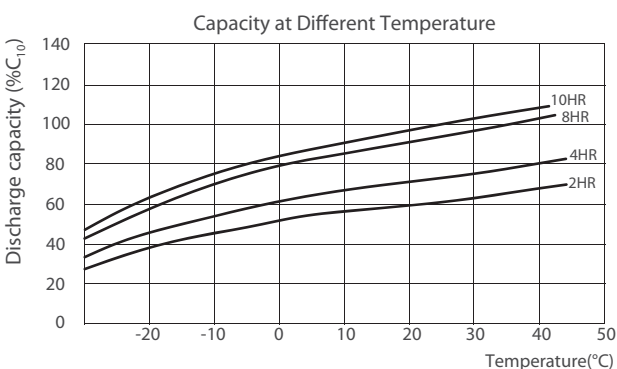
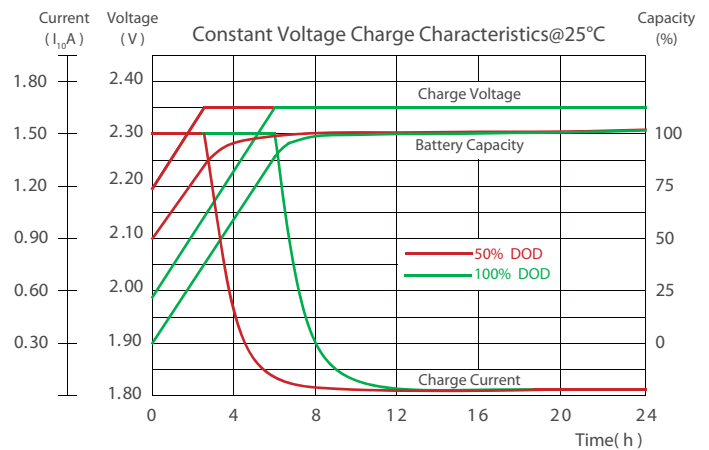
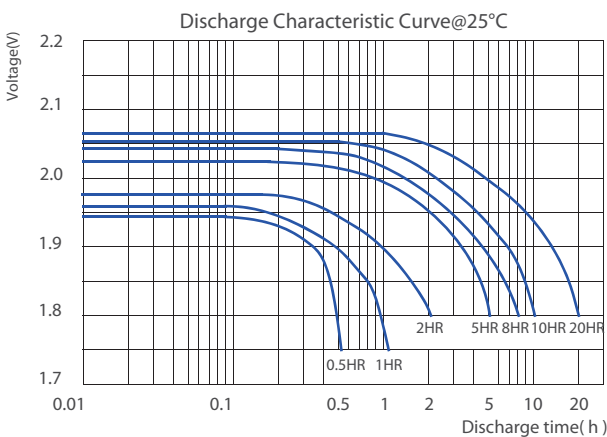

*Declaration:

This information is generally descriptive only and is not intended to make or imply any representation, guarantee or warranty with respect to any cells and batteries. Cell and battery designs/specifications are subject to modification without notice. Contact CHINASHOTO for the latest information.

Welcome to Visit : www.chinashoto.com